



### Typical Features

- ◆ Wide input voltage range 3:1
- ◆ High efficiency up to 92%
- ◆ Low no-load power consumption
- ◆ Operating Temperature: -40°C to +105°C
- ◆ High isolation voltage, input-output 2500VAC, input-case 2100VAC
- ◆ Protection: Input under/over voltage, output over voltage, over current, over temp, short circuit
- ◆ Standard brick size

Conform to CE standard

**ZAA700-220S48** high efficiency brick ac-dc converter, rated input voltage 220VAC, output 48V/700W, no minimum load, wide input 90-286VAC, regulated single output, high isolation insulation voltage, allowing operating temperature up to 105 °C, with input under/over voltage protection, output over-current, over-voltage, over-temperature, short-circuit protection, remote control and remote compensation, output voltage regulation and other functions.

### Typical Product List

Part no	Input voltage range (VAC)	Output power (W)	Output voltage (VDC)	Output current (A)	Ripple & Noise (mV)	Full load efficiency(%) Min/Typ.	Note
ZAA700-220S48	90-286	700	48	14.5	480	90/92	Standard
ZAA700-220S48-H							Heatsink

Note: When the input is below 154VAC and 200VDC, the output load capacity is linearly derated. When inputting 90VAC/140VDC, the stable output power is 500W.

### Input Specification

Item	Operating conditions	Min.	Typ.	Max.	Unit
AC input starting working voltage		--	--	90	VAC
Ac input under voltage protection		--	--	80	
Ac input over voltage protection		290	--	310	
Input impulse voltage (1sec.max.)	Input beyond this range may cause permanent damage	-0.7	--	315	
Dc input starting working voltage		--	--	145	VDC
Dc input under voltage protection		--	--	135	
Dc input over voltage protection		425	--	435	
Input maximum impulse current	Input line in series 5.6R, 20mm diameter thermal sensitive, 220Vac input	--	--	40	A
Input voltage frequency		47	--	63	Hz
Start-up time		--	--	5	S
Standby power consumption	220Vac input	--	10	20	W
PF value	220Vac input, full load output	95	--	--	%

**Output Specification**

Item	Operating conditions	Min.	Typ.	Max.	Unit
Output voltage accuracy	Nominal input voltage, 0%-100% load	--	±0.2	±1.0	%
Linear regulation rate	Full load, input voltage from low to high	--	±0.1	±0.2	
Load regulation rate	Nominal input voltage, 10%-100% load	--	±0.1	±0.2	
Transient recovery time	25% load step change (step rate 1A/50uS)	--	200	250	uS
Transient response deviation		-5	--	5	%
Temperature drift coefficient	Full load	-0.02	--	+0.02	%/°C
Ripple & Noise	20M bandwidth, external capacitance test above 680uF	--	240	480	mVp-p
Output voltage adjustment (TRIM)		38.4	--	52.8	VDC
Output voltage remote compensation (Sense)		--	--	5	%
Over temp protection	Maximum temperature of product metal substrate surface	105	115	125	°C
Output over voltage protection		125	--	150	%
Output over current protection		15.2	--	18.8	A
Output short circuit protection		Hiccup, continuous, self-recovery			

**General Specification**

Item	Operating conditions		Min.	Typ.	Max.	Unit
Isolation Voltage	I/P-O/P	Test 1min, leakage current < 3mA	--	--	2500	VAC
	I/P-Case	Test 1min, leakage current < 3mA	--	--	2100	VAC
	O/P-Case	Test 1min, leakage current < 3mA	--	--	500	VAC
Insulation resistance	I/P-O/P	Insulation voltage 500VDC	100	--	--	MΩ
MTBF			150	--	--	K hours

**Environmental characteristics**

Item	Operating conditions	Min.	Typ.	Max.	Unit
Operating Temperature	See temperature derating curve	-40	--	+105	°C
Storage Humidity	No condensing	5	--	95	%RH
Storage Temperature		-40	--	+125	°C
Soldering resistance of pins	The solder joint is 1.5mm away from the shell, and the soldering time< 1.5S	--	--	+350	
Cooling requirements		EN60068-2-1			
Dry heat requirement		EN60068-2-2			
Damp heat requirement		EN60068-2-30			
Shock and vibration		IEC/EN 61373 Body 1 Class B			

**EMC Characteristics(EN55032)**

Item	Item	Standard	Limit	Criteria
EMI	CE	EN55032-3-2	150kHz-500kHz 66dBuV	
		EN55032-2-1	500kHz-30MHz 60dBuV	
	RE	EN55032-3-2	30MHz-230MHz 50dBuV/m at 3m	
		EN55032-2-1	230MHz-1GHz 57dBuV/m at 3m	
EMS	ESD	EN55032-3-2	Contact ±6KV/Air ±8KV	perf. Criteria A
	RS	EN55032-3-2	10V/m	perf. Criteria A
	EFT	EN55032-3-2	±2kV 5/50ns 5kHz	perf. Criteria A

Surge	EN55032-3-2	line to line ± 1KV (42Ω, 0.5μF)	perf. Criteria A
CE	EN55032-3-2	0.15MHz-80MHz 10 Vr.m.s	perf. Criteria A

**Physical Characteristics**

Case Materials	Metal bottom shell + black flame retardant material shell (UL94 V-0)
Heat sink	Dimension 116.8*61*20mm, weight 150g, aluminum alloy, anodized black
Cooling method H	Conduction cooling or forced air cooling
Product Weight	Standard 250g, with heatsink 402g

**Dimension and Pin-Out**

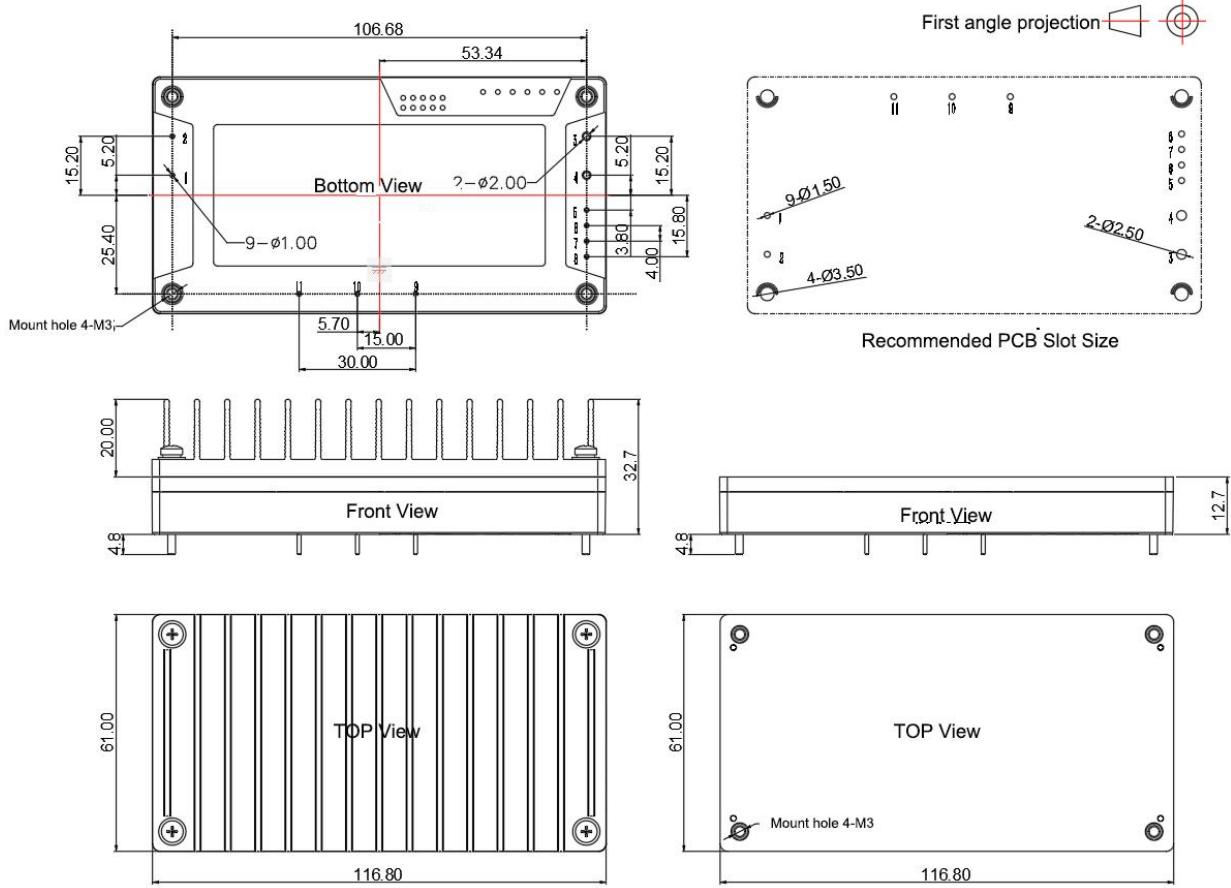

Standard+Heatsink  
**116.8\*61.0\*32.7mm**

Standard  
**116.8\*61.0\*12.7mm**

- Note:  
unit:mm  
Pin1,2,5,6,7,8,9,10,11 dia:1.00  
Pin3,4 dia:2.00  
general tolerance:X.X±0.5, X.XX±0.1  
mounting hole tightening torque: Max 0.4N\*m

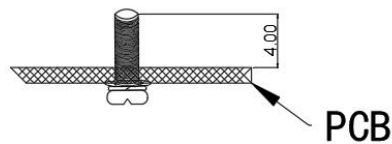

No	1	2	3	4	5	6
Pin-out	AC(L)	AC(N)	-Vo	+Vo	-S	+S
No	7	8	9	10	11	
Pin-out	TRIM	ENA	-BC	+BC	R	

Note: 1. ENA is the output status signal, and when the power supply is working normally, ENA shows low impedance; When the power supply operates abnormally, ENA exhibits high impedance and the maximum pulling current is 10mA;

**Product characteristic curve**

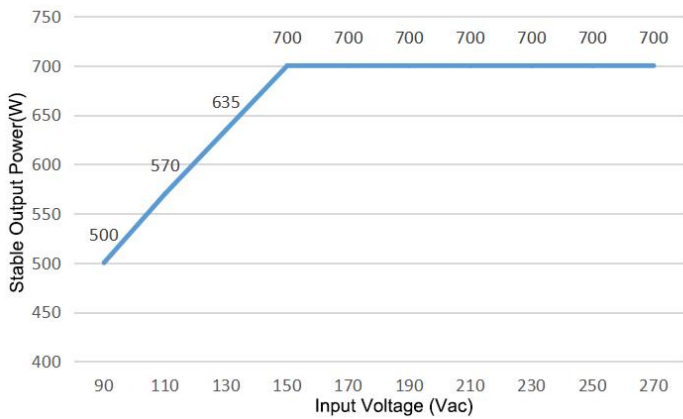
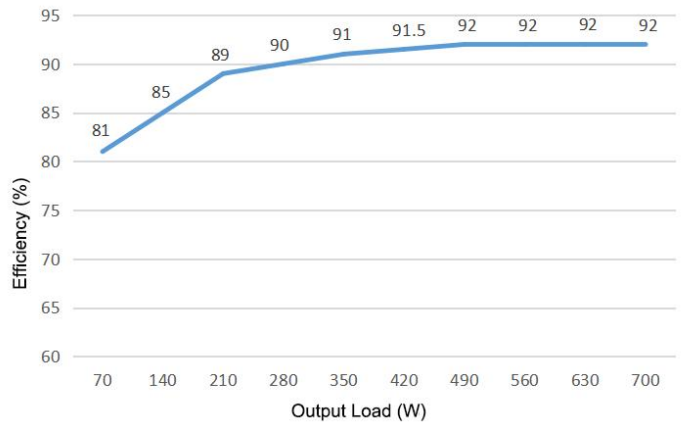
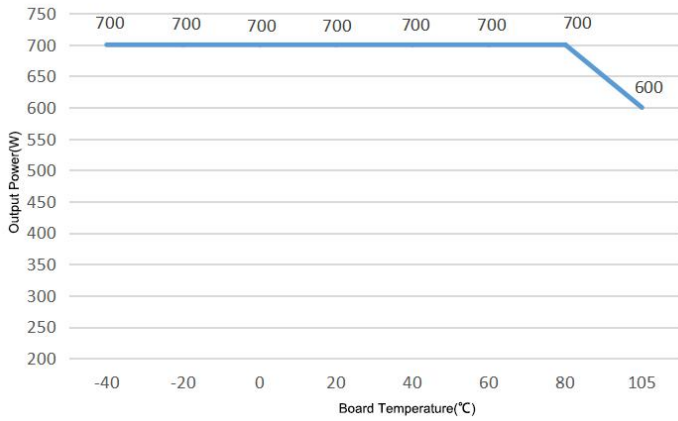

**Notes**

1. The temperature derating curve and efficiency curve are both typical values tested;
2. The temperature derating curve is tested according to our laboratory testing conditions. If the actual environmental conditions used by the customer are inconsistent, it is necessary to ensure that the temperature of the aluminum shell of the product does not exceed 105 °C and can be used within any rated load range.

**Reference**

1. Recommended application circuit.

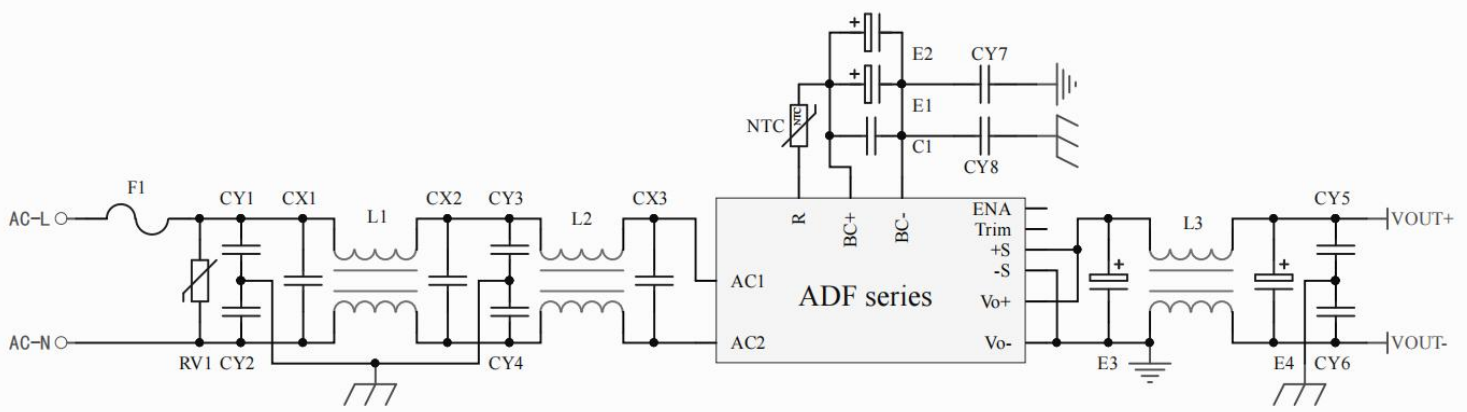

F1	AC250V 10A fuse
RV1	14D 620V varistor
CX1,CX2,CX3	AC250V 1uF X2 capacitor
CY1,CY2,CY3,CY4,CY8	1000pF 250VAC Y2 capacitor
CY7	470pF 250VAC Y1 capacitor

L1,L2	6.0mH common mode inductor, rated current not less than 7.5A
E1,E2	450V 330uF electrolytic capacitor
C1	1uF 630V polypropylene capacitor
NTC	5.6 Ω 20mm thermistor
E3, E4	680uF 63V electrolytic capacitor
CY5,CY6	10nF 2KV ceramic chip capacitor
L3	50uH common mode inductor, rated current not less than 15A

Note: There are limited requirements for the selection of capacitors CX3, C1, E1, and E2 in the recommended circuits above; CX3 and C1 must  $\geq 1 \mu\text{F}$  capacitance; The capacity after E1 and E2 are connected in parallel must  $\geq 440 \mu\text{F}$ ; the NTC resistor must be installed; if this restriction is not followed, the power supply may be damaged.

**2. Sense usage and precautions**

(1) Without far-end

compensation:

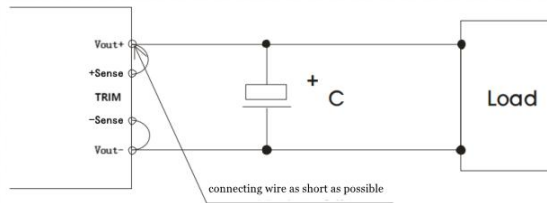

Precautions:

1. Do not use remote compensation, make sure Vout+ and Sense+, Vout- and Sense- are short-circuited;
2. The connection between Vout+ and Sense+, Vout- and Sense- should be as short as possible and close to the pins, otherwise the module may become unstable.

(2) Using remote

compensation

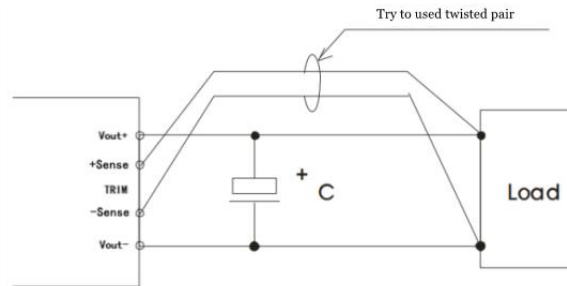

Precautions:

1. When the long-end compensation lead is used, the output voltage may be unstable;
2. If remote compensation is used, please use twisted pair or shielded wire, and keep the lead wire as short as possible;
3. Please use wide PCB leads or thick wires between the power module and the load, and keep the line voltage drop below 0.3V to ensure that the power output voltage remains within the specified range;
4. The impedance of the leads may cause the output voltage to oscillate or have larger ripples. Please verify it before use.

**3. Use of TRIM and calculation of TRIM resistance**

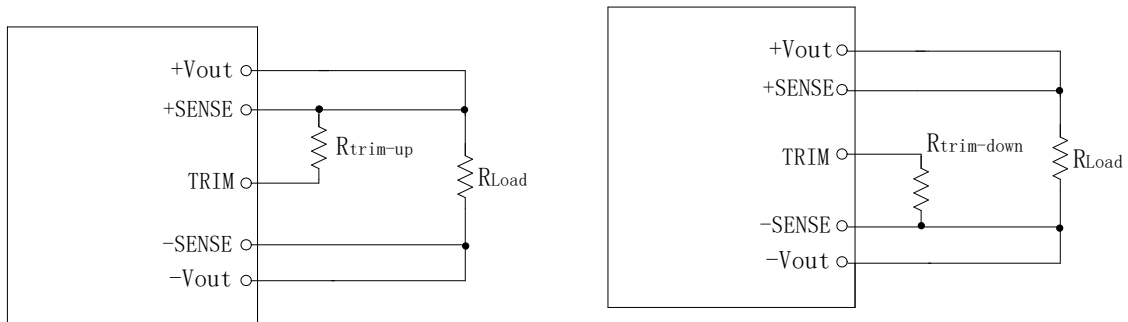

The external resistance is applied between the TRIM terminal and the  $\pm$  SENSE terminal, which can increase or decrease the output voltage within the range of 66.6% -107% Vout. When a resistor is applied between the TRIM terminal and the +SENSE terminal, the output voltage increases; The resistor

is applied between the TRIM and - SENSE terminals, resulting in a decrease in output voltage. During adjustment, adjust the resistance as close as possible to the lead of the module power supply. When this function is not needed, the TRIM end is suspended.

$$R_{\text{trim-up}} = (5.1 * \Delta * V_o - 12.75) / (2.5 * \Delta - 2.5) - 10.2 \text{ (K}\Omega\text{)}$$

$$R_{\text{trim-down}} = (10.2 * \Delta - 5.1) / (1 - \Delta) \text{ (K}\Omega\text{)}$$

For example, it is necessary to increase the output voltage to 52.8V,  $V_o=48V$ ;  $\Delta= 52.8/48=1.1$ . Bring in formula

$$R_{\text{trim up}} = (5.1 * 1.1 * 48 - 12.75) / (2.5 * 1.1 - 2.5) - 10.2 = 1026.12$$

It is necessary to lower the output voltage to 43.2V,  $\Delta= 43.2/48=0.9$ . Bring in formula

$$R_{\text{trim down}} = (10.2 * 0.9 - 5.1) / (1 - 0.9) = 40.8$$

## Others

- 1 The warranty period of this product is two years. During the normal damage, it will be repaired free of charge. Damages caused by errors in the use method or manufacturing technology, a paid service is provided.
- 2 Our company can provide product customization and matching filter modules. For details, please contact our technical staff directly.

### Guangzhou Aipu Electron Technology Co., Ltd

Address: Building 4, HEDY Park, No.63, Punan Road, Huangpu Dist, Guangzhou, China.

Tel: 86-20-84206763 Fax: 86-20-84206762 HOTLINE: 400-889-8821

E-mail: sales@aipu-elec.com Website: www.aipupower.com